

This article was downloaded by:

On: 23 January 2011

Access details: *Access Details: Free Access*

Publisher *Taylor & Francis*

Informa Ltd Registered in England and Wales Registered Number: 1072954 Registered office: Mortimer House, 37-41 Mortimer Street, London W1T 3JH, UK



## Journal of Coordination Chemistry

Publication details, including instructions for authors and subscription information:

<http://www.informaworld.com/smpp/title~content=t713455674>

### FEATURES OF A FLEXIBLE BACKBONE IN THE COORDINATION COMPOUNDS OF A DIOXIME LIGAND: THE CHARACTERIZATION OF SUPRAMOLECULAR AND DINUCLEAR METAL COMPLEXES

Mohamed M. Aly<sup>a</sup>

<sup>a</sup> Department of Chemistry, Faculty of Science, El-Menoufia University, Shebin, El-Kom, Egypt

**To cite this Article** Aly, Mohamed M.(1999) 'FEATURES OF A FLEXIBLE BACKBONE IN THE COORDINATION COMPOUNDS OF A DIOXIME LIGAND: THE CHARACTERIZATION OF SUPRAMOLECULAR AND DINUCLEAR METAL COMPLEXES', *Journal of Coordination Chemistry*, 47: 4, 505 – 521

**To link to this Article:** DOI: 10.1080/00958979908024350

**URL:** <http://dx.doi.org/10.1080/00958979908024350>

PLEASE SCROLL DOWN FOR ARTICLE

Full terms and conditions of use: <http://www.informaworld.com/terms-and-conditions-of-access.pdf>

This article may be used for research, teaching and private study purposes. Any substantial or systematic reproduction, re-distribution, re-selling, loan or sub-licensing, systematic supply or distribution in any form to anyone is expressly forbidden.

The publisher does not give any warranty express or implied or make any representation that the contents will be complete or accurate or up to date. The accuracy of any instructions, formulae and drug doses should be independently verified with primary sources. The publisher shall not be liable for any loss, actions, claims, proceedings, demand or costs or damages whatsoever or howsoever caused arising directly or indirectly in connection with or arising out of the use of this material.

## FEATURES OF A FLEXIBLE BACKBONE IN THE COORDINATION COMPOUNDS OF A DIOXIME LIGAND: THE CHARACTERIZATION OF SUPRAMOLECULAR AND DINUCLEAR METAL COMPLEXES

MOHAMED M. ALY

*Department of Chemistry, Faculty of Science, El-Menoufia University,  
Shebin El-Kom, Egypt*

*(Received 9 May 1998; Revised 25 August 1998; In final form 2 October 1998)*

The grinding of a 2 : 1 molar ratio mixture of isonitrosoacetylacetone and 1,3-diaminopropan-2-ol led to formation of the tribasic ligand ( $H_3L$ ), (**1**) with two oxime groups and a flexible alcoholic backbone. The 1 : 2 molar ratio reaction of (**1**) with  $CuX_2$  produced the planar dinuclear complexes  $LCu_2(X) \cdot nH_2O$ ; X = acetate (**2**), phenylacetate (**3**), formate (**4**), monochloroacetate (**5**), dichloroacetate (**6**), trichloroacetate (**7**), benzoate (**8**), and *p*-hydroxybenzoate (**9**);  $n = 1$  for (**2**) and (**8**);  $n = 2$  for (**3**)–(**7**); and  $n = 4$  for (**9**). The copper(II) ions are bridged by the carboxylate and the alcoholic oxygen. The strong antiferromagnetic interactions in (**2**)–(**9**) are impeded in (**5**)–(**7**) by the chloroacetate bridge withdrawing electron density from the carboxylate. The latter bridge is replaced by picrate in the 1 : 1 molar ratio reaction of (**2**) with picric acid (**10**). The 1 : 1 molar ratio reaction of (**1**) with copper(II) acetate produced the tetranuclear  $[HLCu]_2[LCu_2(OAc)] \cdot 5H_2O$  (**11**), whereas the 2 : 1 molar ratio reaction, similar to the reaction which led to (**8**), produced  $HLCu$  (**12**). The latter complex reacted (1 : 1 molar ratio) with either copper(II) acetate or nickel(II) acetate to produce complexes (**2**) and the heterodinuclear  $LNiCu(OAc) \cdot 2H_2O$  (**13**), respectively. Similar reactions with (**11**) gave the same complexes (**2**) and (**13**). The acid adducts of (**9**) with *p*-hydroxybenzoic acid (**14**) and  $LCu_2(X) \cdot HX$  (**15**); X = *p*-aminobenzoic acid were isolated. The cobalt(II) analogue of the mononuclear (**12**),  $HLCu \cdot 2H_2O$  (**16**) was obtained from the 1 : 1 molar reaction of (**1**) with cobalt(II) acetate. The supramolecular structure of (**11**), (**12**) and (**16**) took place via intermolecular hydrogen bonding of the alcoholic proton with the oximato oxygen of the adjacent molecule which mediated electron density and allowed for a magnetic exchange interaction. The suggested structures of the ligand and metal complexes are in accordance with analytical, spectral and magnetic moment data.

**Keywords:** Flexible backbone; coordination compounds of dioxime; supramolecular complexes; dicopper(II) complexes

## INTRODUCTION

The versatile coordination chemistry of dinuclear copper(II) complexes stems from their structural relationship to metalloenzymes.<sup>1-3</sup> Metal complexes of Schiff bases have served as metallo-biosite models.<sup>3,4</sup> The bioactivity indicated by oximes and their metal complexes was related<sup>5</sup> to the coordination mode of the oxime sites<sup>6,7</sup> (N and O coordination modes) as well as to the bridging capacity<sup>8-10</sup> of the coordinated oximato group to transition metal ions. Our earlier studies concerning the transition metal complexes of vicinal oxime-imine ligands revealed that the bridging oxygen atom of the oximato group could serve as a binding site for developing supramolecular structures.<sup>11-14</sup> Enormous coordinative flexibility was shown<sup>15-21</sup> by the alcoholic or the terminal oxygen of the transition metal complexes of the Schiff bases ( $N_2O_3$  chromophore) derived from condensation of two molecules of either salicylaldehyde (terminal ligand is salicylaldimine (salim)) or acetylacetonone (terminal ligand is acetylacetonimine (acim)) with one molecule of 1,3-diaminopropan-2-ol. The dicopper(II) complexes of these ligands were subjected<sup>15-17</sup> to extensive investigations in relation to the active centers in type-3 copper proteins. However, it was recently concluded that the dioxygen is bound as peroxide in oxyhaemocyanin and there is no endogenous bridge.<sup>4,22</sup>

The biological and the magneto-structural relationships resulting from the  $N_2O_3$  chromophore<sup>15-21</sup> have prompted us to investigate the structural and coordinative implications of the  $N_4O$  set of the tribasic pentadentate Schiff-base ligand ( $H_3L$ ) derived from condensation of two molecules of isonitrosoacetylacetonone (Hisoacac) with one molecule of 1,3-diaminopropan-2-ol (terminal ligand is isonitrosoacetylacetonimine, (isoacim)). Our objective in the present study is three-fold concerning the flexibility of the alcoholic backbone of ( $H_3L$ ): (i) The cooperative coordination of the copper(II) ion; (ii) the increased ligand field of the  $N_4O$  chromophore as compared to that of a  $N_2O_3$  set and (iii) the effect of electron density in the bridging exogenous pathway of the dinuclear copper(II) complexes on the extent of paramagnetic interaction. Part of this investigation had been briefly described.<sup>23</sup>

## EXPERIMENTAL

Reagent grade chemicals were used throughout. The IR spectra of the metal complexes were measured as KBr pellets using a Shimadzu IR 470 infrared

spectrophotometer. The electronic spectra were recorded with a Shimadzu UV 3101 UV-vis scanning spectrophotometer. Magnetic susceptibilities were measured at 25°C by the Guoy method as described in our earlier reports<sup>7,11,13,14</sup> where  $\text{Hg}[\text{Co}(\text{CNS})_4]$  was used as the magnetic susceptibility standard and diamagnetic corrections were affected by employing standard constants. The magnetic moments were calculated from the equation  $\mu_{\text{eff}} = 2.83 \sqrt{\chi_{\text{M}}^{\text{corr}} \cdot T}$ . C, H and N analyses were determined at the analytical unit of the Kuwait University. Standard methods were used for the determination of metal ions. The metal acetates  $\text{M}(\text{OAc})_2 \cdot n\text{H}_2\text{O}$  ( $\text{M} = \text{Cu}$ ,  $n = 1$ ;  $\text{M} = \text{Ni}$  or  $\text{Co}$ ,  $n = 4$ ) were used. The copper(II) salts ( $\text{CuX}_2$ ) were prepared from the 1 : 2 molar ratio reaction of either copper metal with the acid in EtOH ( $\text{HX} =$  phenylacetic, formic, monochloroacetic, dichloroacetic, trichloroacetic or *p*-hydroxybenzoic acid) or copper(II) acetate with the acid ( $\text{HX} =$  benzoic or *p*-aminobenzoic acid). The ligand and metal complexes were dried *in vacuo* over  $\text{P}_4\text{O}_{10}$ .

#### **Preparation of the Ligand $\text{H}_3\text{L}$ (1,3-bis(isonitrosoacetylacetonimine)-propan-2-ol); Compound (1)**

This compound was prepared by grinding a powdered mixture obtained by the gradual addition of isonitrosoacetylacetone (0.04 mol) to 1,3-diaminopropan-2-ol (0.02 mol). The grinding process was continued for 2 h to produce a yellow paste, which was digested in diethyl ether whereby the yellow compound (1) was obtained. This was filtered off, washed several times with diethyl ether and dried *in vacuo* over  $\text{P}_4\text{O}_{10}$  for 24 h. The grinding and drying process was repeated once again (m.p. 101°C). The attempted reaction in ethanol or chloroform led to formation of a yellow-brown solution from which the solid ligand could not be isolated.

#### **Preparation of Complex (2)**

An ethanolic solution (100 cm<sup>3</sup>) of copper(II) acetate (0.0128 mol) was added to a solution (EtOH, 50 cm<sup>3</sup>) of compound (1) (0.0064 mol) dropwise while stirring. The resulting brown solution was refluxed for 3 h, left to cool and the precipitated complex (2) was filtered off and washed with ethanol. The powdered complex (2) (0.002 mol) was stable after refluxing in EtOH, MeOH or  $\text{CHCl}_3$  (50 cm<sup>3</sup>). The complex was recovered unchanged (0.002 mol) from its 1 : 1 molar ratio reaction with phenol in refluxing ethanol (100 cm<sup>3</sup>) for 1 h.

### Preparation of Complex (3)

The chloroform solution (40 cm<sup>3</sup>) of picric acid (0.004 mol) was added, dropwise while stirring, to the powdered suspension of complex (2) (0.004 mol) in chloroform (100 cm<sup>3</sup>). The warmed reaction mixture was stirred for 5 h and the precipitated complex was filtered off and washed with chloroform.

### Preparation of Complexes (4) and (5)

Complex (4) was prepared in EtOH from the 1 : 1 molar ratio reaction of copper(II) acetate with compound (1) using the procedure described above for complex (2). The 1 : 2 molar ratio reaction of complex (4) (0.0011 mol, 50 cm<sup>3</sup>) in EtOH with copper(II) acetate (0.0022 mol, 50 cm<sup>3</sup>) was carried out by adding the metal acetate solution to the powdered suspension of the complex dropwise while stirring. The reaction mixture was boiled under reflux for 3 h and the precipitated complex (2) was filtered off and washed with EtOH. Similar reaction with nickel(II) acetate led to the separation of complex (2). Complex (5) was obtained by concentrating the filtrate to about half of its volume. The precipitated complex was filtered off and washed several times with warm ethanol.

### Preparation of Complex (6)

This complex was prepared from the 2 : 1 molar ratio reaction of compound (1) with copper(II) benzoate in EtOH as described above for complex (2). The reactions of complex (6) with copper(II) acetate or nickel(II) acetate (1 : 1 molar ratio) were carried out, as described above for similar reactions of complex (4) to produce complexes (2) and (5), respectively.

### Preparation of Complexes (7)–(15)

These complexes were prepared from the 1 : 2 molar ratio reaction of compound (1) with copper(II) salts CuX<sub>2</sub> (X = phenylacetate, formate, monochloroacetate, dichloroacetate, trichloroacetate and benzoate for complexes (7), (8), (9), (10), (11) and (12), respectively) in EtOH (except for copper(II) formate which was dissolved in water). The applied procedure is identical with that described above for complex (2). Similar reaction with copper(II) *p*-hydroxybenzoate led to the immediate precipitation of the green-brown complex (13) which was filtered off and washed with EtOH. On concentrating the filtrate of this reaction to about half its volume and leaving for 24 h

the dark-brown complex (14) was precipitated which was filtered off and washed with ethanol. The 1:2 molar ratio reaction of compound (1) with copper(II) *p*-aminobenzoate in EtOH produced only the green-brown complex (15). The attempted isolation of any other complex (comparable with the brown complex (14)) from the filtrate was unsuccessful.

### Preparation of Complex (16)

An ethanolic solution (150 cm<sup>3</sup>) of cobalt acetate (0.0064 mol) was added, dropwise while stirring, to the warmed solution (EtOH, 50 cm<sup>3</sup>) of an equimolar concentration of compound (1). The resulting solution was warmed for 1 h, filtered from the suspended impurities and warmed again for 2 h to precipitate complex (16) which was filtered off and washed with ethanol.

*Compound (1)* H<sub>3</sub>L, yellow. *Anal.* Calcd. for C<sub>13</sub>H<sub>20</sub>N<sub>4</sub>O<sub>5</sub> (%): C, 49.99; H, 6.46; N, 17.94. Found: C, 49.82; H, 6.73; N, 18.29.

*Complex (2)* LCu<sub>2</sub>(OAc)·H<sub>2</sub>O, brown. *Anal.* Calcd. for C<sub>15</sub>H<sub>22</sub>N<sub>4</sub>O<sub>8</sub>·Cu<sub>2</sub> (%): C, 35.09; H, 4.32; N, 10.91; Cu, 24.75. Found: C, 34.82; H, 4.40; N, 11.36; Cu, 24.70.

*Complex (3)* LCu<sub>2</sub>(pic)·H<sub>2</sub>O, brown-green. *Anal.* Calcd. for C<sub>19</sub>H<sub>21</sub>N<sub>7</sub>O<sub>12</sub>Cu<sub>2</sub> (%): C, 34.24; H, 3.18; N, 14.71; Cu, 19.07. Found: C, 34.30; H, 3.32; N, 15.00; Cu, 18.82.

*Complex (4)* [LCu<sub>2</sub>(OAc)][HLCu]<sub>2</sub>·5H<sub>2</sub>O, brown. *Anal.* Calcd. for C<sub>41</sub>H<sub>64</sub>N<sub>12</sub>O<sub>23</sub>Cu<sub>4</sub> (%): C, 36.99; H, 4.85; N, 12.63; Cu, 19.10. Found: C, 36.79; H, 5.13; N, 12.91; Cu, 19.44.

*Complex (5)* LNiCu(OAc)·2H<sub>2</sub>O, brown-green. *Anal.* Calcd. for C<sub>15</sub>H<sub>24</sub>N<sub>4</sub>O<sub>9</sub>NiCu (%): C, 34.21; H, 4.59; N, 10.64; Ni, 11.15; Cu, 12.07. Found: C, 33.93; H, 4.68; N, 10.89; Ni, 10.83; Cu, 12.02.

*Complex (6)* HLCu, brown. *Anal.* Calcd. for C<sub>13</sub>H<sub>18</sub>N<sub>4</sub>O<sub>5</sub>Cu (%): C, 41.77; H, 4.85; N, 15.00; Cu, 17.00. Found: C, 42.09; H, 5.03; N, 15.01; Cu, 16.83.

*Complex (7)* LCu<sub>2</sub>(phenac)·2H<sub>2</sub>O, brown. *Anal.* Calcd. for C<sub>21</sub>H<sub>28</sub>N<sub>4</sub>O<sub>9</sub>Cu<sub>2</sub> (%): C, 41.50; H, 4.65; N, 9.22; Cu, 20.92. Found (%): C, 41.50; H, 4.61; N, 9.54; Cu, 20.69.

*Complex (8)* LCu<sub>2</sub>(formate)·2H<sub>2</sub>O, brown. *Anal.* Calcd. for C<sub>14</sub>H<sub>22</sub>N<sub>4</sub>O<sub>9</sub>Cu<sub>2</sub> (%): C, 32.50; H, 4.28; N, 10.83; Cu, 24.56. Found (%): C, 32.59; H, 4.21; N, 10.57; Cu, 24.48.

*Complex (9)* LCu<sub>2</sub>(OAc)<sub>1</sub>·2H<sub>2</sub>O, brown. *Anal.* Calcd. for C<sub>15</sub>H<sub>19</sub>N<sub>4</sub>O<sub>7</sub>ClCu<sub>2</sub> (%): C, 31.84; H, 4.10; N, 9.90; Cl, 6.27; Cu, 22.46. Found (%): C, 31.54; H, 4.01; N, 9.58; Cl, 6.25; Cu, 22.50.

**Complex (10)**  $\text{LCu}_2(\text{OAc}_2) \cdot \text{H}_2\text{O}$ , brown. *Anal.* Calcd. for  $\text{C}_{15}\text{H}_{22}\text{N}_4\text{O}_9\text{Cl}_2\text{Cu}_2$  (%): C, 30.01; H, 3.69; N, 9.33; Cl, 11.81; Cu, 21.17. Found (%): C, 30.10; H, 3.72; N, 9.58; Cl, 12.10; Cu, 21.11.

**Complex (11)**  $\text{LCu}_2(\text{OAc}_3) \cdot 2\text{H}_2\text{O}$ , brown. *Anal.* Calcd. for  $\text{C}_{15}\text{H}_{21}\text{N}_4\text{O}_9\text{Cl}_3\text{Cu}_2$  (%): C, 28.38; H, 3.33; N, 8.83; Cl, 16.75; Cu, 20.02. Found (%): C, 28.02; H, 3.42; N, 8.65; Cl, 16.28; Cu, 20.22.

**Complex (12)**  $\text{LCu}_2(\text{bz}) \cdot \text{H}_2\text{O}$ , brown. *Anal.* Calcd. for  $\text{C}_{20}\text{H}_{24}\text{N}_4\text{O}_8\text{Cu}_2$  (%): C, 41.74; H, 4.20; N, 9.73; Cu, 22.08. Found (%): C, 42.12; H, 4.34; N, 10.08; Cu, 22.10.

**Complex (13)**  $\text{LCu}_2(\text{Hdbz})(\text{H}_2\text{dbz})$ , green-brown. *Anal.* Calcd. for  $\text{C}_{27}\text{H}_{30}\text{N}_4\text{O}_{11}\text{Cu}_2$  (%): C, 45.44; H, 4.24; N, 7.85; Cu, 17.81. Found (%): C, 45.21; H, 4.27; N, 7.70; Cu, 17.44.

**Complex (14)**  $\text{LCu}_2(\text{Hdbz}) \cdot 4\text{H}_2\text{O}$ , dark-brown. *Anal.* Calcd. for  $\text{C}_{20}\text{H}_{32}\text{N}_4\text{O}_{12}\text{Cu}_2$  (%): C, 37.10; H, 4.98; N, 8.65; Cu, 19.63. Found (%): C, 37.40; H, 4.93; N, 8.66; Cu, 19.79.

**Complex (15)**  $\text{LCu}_2(\text{abz})(\text{Habz})$ , green-brown. *Anal.* Calcd. for  $\text{C}_{27}\text{H}_{30}\text{N}_6\text{O}_9\text{Cu}_2$  (%): C, 45.70; H, 4.26; N, 11.84; Cu, 17.91. Found (%): C, 45.50; H, 4.31; N, 11.44; Cu, 18.13.

**Complex (16)**  $\text{HLCu} \cdot 2\text{H}_2\text{O}$ , red. *Anal.* Calcd. for  $\text{C}_{13}\text{H}_{22}\text{N}_4\text{O}_7\text{Cu}$  (%): C, 38.53; H, 5.47; N, 13.82; Cu, 14.54. Found (%): C, 38.88; H, 5.32; N, 13.65; Cu, 14.24.

## RESULTS AND DISCUSSION

The reactions that led to formation of the ligand ( $\text{H}_3\text{L}$ ) and the metal complexes are schematically represented in Figure 1. These metal complexes are stable at room temperature, decompose above  $200^\circ\text{C}$  and have low molar conductance values in chloroform ( $< 2.0\Omega^{-1}\text{cm}^2\text{mol}^{-1}$ ) indicating their non-ionic character. The presence of the lattice component and coordinated water in the metal complexes are confirmed by T.G.A. The suggested structures of the metal complexes are based on the analytical data (detailed in the experimental section), vibrational spectra (Table I), electronic spectra and magnetic moment (Table II).

The repeated grinding of the 2:1 molar ratio powdered mixture of (Hisoacac) with 1,3-diaminopropan-2-ol led to formation of the pentadentate ligand  $\text{H}_3\text{L}$ , compound (1) (Figure 1). This ligand had a terminal isonitroacetylacetonimine (isoacim) with two oxime groups<sup>6-14,24</sup> and an alcoholic function<sup>15-18</sup> which are separately known to be very reactive sites. The two  $\nu(\text{OH})$  vibrations are broad and shifted to lower frequency<sup>21</sup>

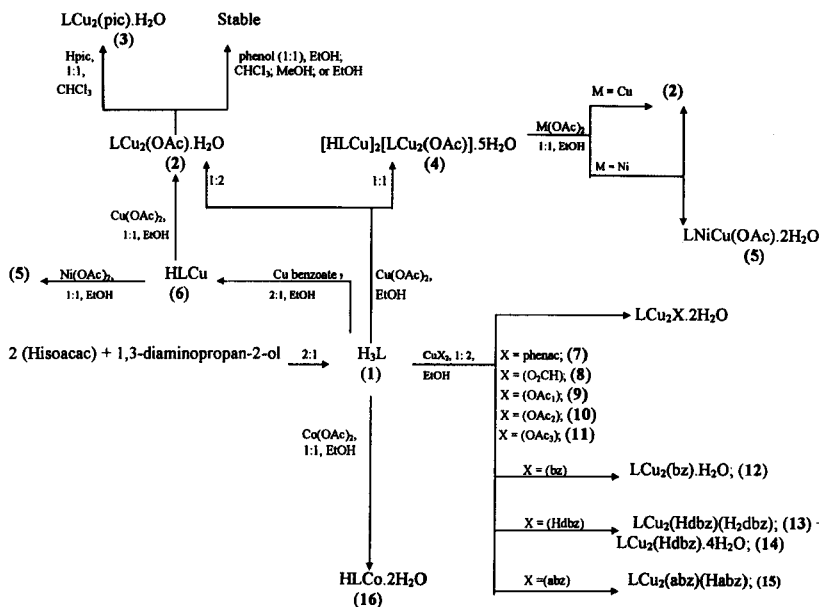

FIGURE 1 Schematic representation for the reaction of the pentadentate ligand  $H_3L$  (derived from the condensation of two molecules of (Hisoacac) with one molecule of 1,3-diaminopropan-2-ol) with Cu(II) and Co(II) ions, AcOH, Ac<sub>1</sub>OH, Ac<sub>2</sub>OH and Ac<sub>3</sub>OH refer to acetic, monochloro-, dichloro-, and trichloroacetic acid, respectively; (O<sub>2</sub>CH) = formate; (Hisoacac) = isonitrosoacetylacetone; (Hpic) = picric acid; (phenac) = phenylacetate; (bz) = benzoate; (H<sub>2</sub>dbz) = *p*-hydroxybenzoic acid; (Habz) = *p*-aminobenzoic acid.

(3400–2800  $\text{cm}^{-1}$  and overlap with another vibration at 2800–2100  $\text{cm}^{-1}$ ) indicating strongly hydrogen bonded oxime<sup>6–14</sup> and alcoholic functions<sup>21</sup> (intra- or intermolecular) with the basic azomethine nitrogen.

The 1 : 2 molar ratio reaction of compound (1) with copper(II) acetate led to formation of the dicopper(II) complex (2). This complex is characterized by vibrational bands at 1682 and 1150  $\text{cm}^{-1}$  which were associated with the  $\nu(\text{C}=\text{O})$  and  $\nu(\text{N}-\text{O})$ , respectively of the N-coordinated oximato group of the five-membered chelate ring.<sup>7,11,12</sup> The splitting of the latter band is a feature associated with N-coordination by the oximato group.<sup>11,12</sup> The  $\nu(\text{C}=\text{N})$  vibrations are located at comparable locations to those previously reported<sup>7,11,12</sup> for the copper(II) complexes of vicinal oxime–imine ligands. These characteristic vibrations for the five-membered chelate ring are also applicable to complex (3)–(16) in Table I. The  $\nu_{\text{as}}$  vibration of the bridging carboxylate was detected in complex (2) and in complexes (4), (5), (7) and (12)–(15) at the expected location<sup>13,14</sup> of 1565–1540  $\text{cm}^{-1}$ . It was shifted to



TABLE I Vibrational features ( $\text{cm}^{-1}$ ) of the ligand and its metal complexes

Compound	$\nu(\text{OH})$	$\nu(\text{C}=\text{O})$	$\nu(\text{C}=\text{N})$		$\nu_{\text{as}}(\text{carboxylate})$	$\nu(\text{N}-\text{O})$
			Imine	Oxime		
(1)	3400–2800 (br) 2850–2100 (br)	1682 s	1635 s	1622 s	—	1015 s 995 s
(2)	3550–3200 br	1670 s	1600 s	1580 s	1560 s	1150 m 1140 m
(3)	3550–3200 br	1670 s	1605 s	1570 m	—	1150 m 1140 m
(4)	3550–3200 br	1680 s	1590 s	1570 m	1560 s	1160 m 1145 m
(5)	3500–3250 br	1670 s	1600 s	1580 s	1560 s	1160 m 1150 m 1140 m
(6)	3550–3200 br	1680 s	1595 s	1580 s	—	1160 m 1150 m
(7)	3550–3250 br	1680 s	1600 s	1585 s	1565 s	1150 m 1140 m
(8)	3550–3250 br	1680 s	1600 s	1585 s	1570 s	1150 m 1140 m
(9)	3550–3200 br	1680 s	1600 s	1580 s	1590 s	1145 m
(10)	3550–3250 br	1680 s	1600 s	1580 s	1625 s	1160 m 1145 m
(11)	3550–3200 br	1680 s	1600 s	1580 s	1635 s	1155 m 1140 m
(12)	3550–3250 br	1675 s	1600 s	1590	1550 s	1148 m
(13)	3550–3250 br	1680 s	1600 s	1590 s	1550 s	1150 m
(14)	3550–3250 br	1675 s	1600 s	1590 s	1540 s	1140 m
(15)	3550–3250 br	1680 s	1605 s	1590 s	1550 s	1150 m
(16)	3550–3250 br	1680 s	1605 s	1580 s	1540 s	1150 m
					—	1182 m

higher frequency in (8) and in (9)–(11) of the chloroacetates.<sup>13</sup> The electronic spectrum of complex (2) showed a broad  $d-d$  absorption peak at 570 nm, indicative of the square-planar geometry for<sup>25,26</sup> copper(II). This  $d-d$  absorption peak should be distinguished from that of the square pyramidal geometry for copper(II) at higher wavelength (610–670 nm). The same planar geometry around the copper(II) is suggested for complexes (3)–(15) which revealed identical  $d-d$  transition absorption peaks (Table II). The magnetic moment of the complex was found to be 0.90 B.M. (per copper atom) which is lower than the spin only value of the  $d^9$  system of copper(II) of 1.73 B.M. This observation indicates that the antiferromagnetic exchange interaction is stronger in this case than that reported for the same complex (bridging acetate) with the terminal ligand of salicylaldimine<sup>17</sup> (1.61 B.M.). It is even stronger than that of the latter ligand but with bridging pyrozoate<sup>17</sup> (1.38 B.M.) which is known to promote an efficient

TABLE II Electronic spectra and magnetic moment of the ligand and metal complexes

Compound	Solvent <i>N.M. = Nujol Mull</i>	$\lambda_{\max}$ (nm) <sup>a</sup>	Magnetic moment <sup>c</sup> (B.M.)
(1)	EtOH	390 (60), 300 (1130)	Diamagnetic
(2)	N.M.	570 (br)	0.90
	CHCl <sub>3</sub> <sup>b</sup>	570 (br), 360, 295	
(3)	N.M.	570 (br), 420	0.86
	CHCl <sub>3</sub> <sup>b</sup>	570 (br), 400 330	
(4)	N.M.	570 (br)	0.60
	CHCl <sub>3</sub> <sup>b</sup>	565 br, 370, 275	
(5)	N.M.	580 (br), 475 (br)	3.04 <sup>d</sup>
	CHCl <sub>3</sub> <sup>b</sup>	575 (br), 470 (br), 370, 275	
(6)	N.M.	570 (br), 470 (br)	1.15
	CHCl <sub>3</sub> <sup>b</sup>	570 (br), 470, 360, 270	
(7)	N.M.	570 (br)	1.00
	CHCl <sub>3</sub> <sup>b</sup>	560 (br), 340, 305	
(8)	N.M.	570 (br), 450 (br)	1.13
	H <sub>2</sub> O	570 (590), 390 (3100), 300 (7500)	
	CHCl <sub>3</sub> <sup>b</sup>	570 (br), 305	
(9)	N.M.	570 (br)	1.07
	CHCl <sub>3</sub> <sup>b</sup>	570 (br), 370,305	
(10)	N.M.	570 (br)	1.26
	CHCl <sub>3</sub> <sup>b</sup>	570 (br), 305	
(11)	N.M.	570 (br), 430 (br)	1.30
	CHCl <sub>3</sub> <sup>b</sup>	570 (br), 440 (br), 305	
(12)	N.M.	570 (br),415	1.00
	CHCl <sub>3</sub> <sup>b</sup>	570 (br), 370, 315	
(13)	N.M.	570 (br)	0.97
	CHCl <sub>3</sub> <sup>b</sup>	570 (br), 360, 305	
(14)	N.M.	570 (br), 400 (br)	1.03
	CHCl <sub>3</sub> <sup>b</sup>	570 (br), 370, 310	
(15)	N.M.	550 (br), 450	1.06
	CHCl <sub>3</sub> <sup>b</sup>	575 (br), 450, 360, 310, 275	
(16)	N.M.	500 (br)	2.85
	CHCl <sub>3</sub> <sup>b</sup>	500(br), 345, 265	

<sup>a</sup> Values in parentheses are molar absorptivities in  $1 \text{ mol}^{-1} \text{ cm}^{-1}$ .

<sup>b</sup> Saturated solution of the sparingly soluble complex (temperature did not exceed  $40^\circ\text{C}$ ).

<sup>c</sup> Per metal atom at  $298 \text{ K}$ .

<sup>d</sup> Compared with the calculated value<sup>14</sup> of 3.32 B.M. obtained by adding the paramagnetic susceptibilities corresponding to the spin-only magnetic moment of one unpaired electron (copper(II),  $d^9$  system) and two unpaired electrons (nickel(II), high-spin  $d^8$  system) and calculating the magnetic moment from  $\mu_{\text{eff}} = 2.83\sqrt{\chi_M T}$ .

exchange pathway. It is concluded, therefore, that a higher ligand field of the terminal ligand (isoacim) promotes an efficient exchange through the bridging acetate.

The influencing factors in the magnetic exchange interactions of the dicopper(II) complexes of ligands with the  $\text{N}_2\text{O}_3$  chromophore were regarded<sup>16-19</sup> as: (i) the bond angles at the bridging endogenous atom, (ii) the copper-copper distance and (iii) the size of the dihedral angles between the planes containing the copper(II) ions. With a planar structure, the unpaired

electron resides in a  $d_{xy}$  orbital of the copper atom and the lowered anti-ferromagnetic magnetic exchange was ascribed to the counter-complementary effect of the carboxylate on that exchange although this bridge itself is known to conduct an antiferromagnetic interaction<sup>27,28</sup>. Strong antiferromagnetic interaction was reported<sup>29,30</sup> from the dicopper(II) complexes of the phenoxo-bridged pentadentate ligand (compared with the alkoxo-bridged) with a terminal salim, Figure 2.

The reaction of a 1:1 molar ratio complex (2) with picric acid led to replacement of the bridging acetate by the bridging picrate with a phenoxo-bridge (complex (3), Figure 2). The replacement of the acetylacetonate<sup>31</sup> or the acetate<sup>32,13</sup> by the picrate had been reported. The  $\nu(\text{C}-\text{O})$  of the phenolate was detected at the expected location<sup>13</sup> of  $1560\text{ cm}^{-1}$ . The magnetic moment of complex (3) (0.86 B.M. per metal atom) is not noticeably different from that of (2) which implies that the counter-complementary effect of the carboxylate bridge is not the only deciding factor for efficient exchange interaction.

The reaction of a 1:1 molar ratio of copper(II) acetate with compound (1) produced the tetranuclear complex (4) (Figure 3). The suggested supramolecular structure of this complex consists of two molecules of the mononuclear complex (HLCu) which are hydrogen bonded via the alcoholic proton<sup>18</sup> to the oximato oxygen of the dinuclear complex (2). The magnetic moment of this complex (0.60 B.M. per metal atom) is explained by the increased strength of the magnetic exchange interaction through either the bridging oximato group or more likely through a direct spin-spin interaction between the metal atom of the mononuclear units (HLCu). Complex (4) could be crystallized from ethanol and its reactivity with copper(II) or nickel(II) rules out the possibility that it is simply a physical mixture of its components (a molecule of dinuclear unit and two molecules of the mononuclear unit). Thus, the 1:1 molar ratio reaction of complex (4) with copper(II) acetate produced complex (2) whereas its 1:1 molar ratio reaction with nickel(II) acetate led to formation of the latter complex in addition to the heterodinuclear complex (5). The electronic spectrum of the latter complex could be regarded as a composite of the electronic spectrum of the square-planar copper(II) discussed above and that of octahedral<sup>33</sup> nickel(II) (Table II). The magnetic moment of this complex (3.04 B.M.) is compatible with the suggested geometry (one planar copper(II) and one high-spin nickel(II)). The magnetic moment lower than the calculated value (3.32 B.M.; Table II) is indicative of antiferromagnetic exchange interactions between the metal ions. It is of interest to note that the dinickel(II) complex of the corresponding pentadentate ligand with two different terminal ligands

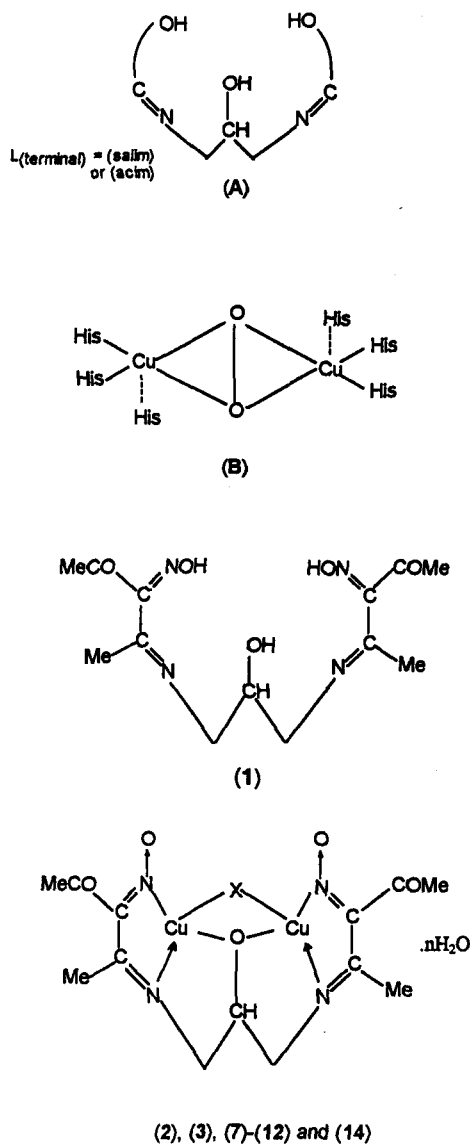
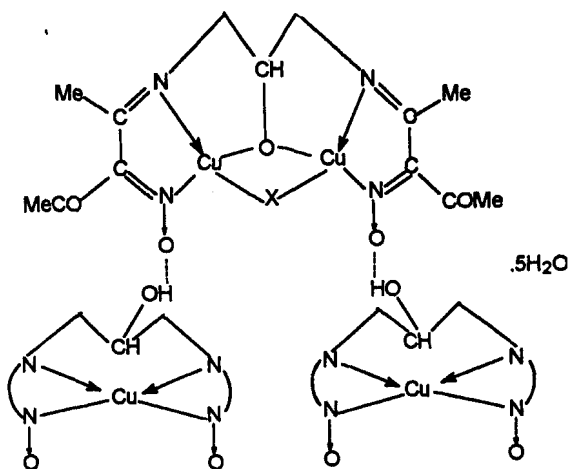
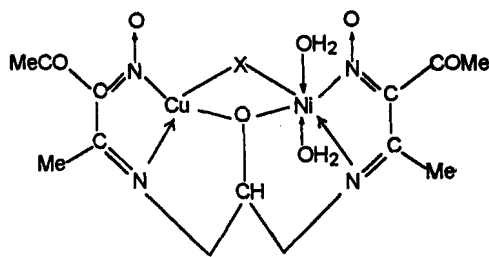

FIGURE 2 (A) The Schiff base with terminal ligand of either salicylaldimine (salim) or acetylacetonimine (acim); (B) schematic representation of the dinuclear site in oxyhaemocyanin (His = histidine). Suggested structures of the ligand  $H_3L$  (compound (1)) and the dinuclear complexes with the bridging unit  $X$  = acetate, picrate, phenylacetate, formate, monochloroacetate, dichloroacetate, trichloroacetate, benzoate and *p*-hydroxybenzoate for complexes (2), (3), (7), (8), (9), (10), (11), (12) and (14) respectively; (see Figure 1 for  $nH_2O$ ).



(4)



(5)

FIGURE 3 Suggested structure for the tetranuclear complex (4) and for the heterodinuclear complex (5); X = acetate.

(acim) and (salim) was recently reported to be square planar and diamagnetic<sup>25</sup> (formulated as  $L_{(\text{salim})(\text{acim})}\text{Ni}_2(\text{pz})$ ; pz = pyrazolate). Several attempts to isolate a pure dinickel(II) complex (from the 1 : 2 molar ratio reactions of compound (1) with nickel(II) acetate in EtOH or water) were not successful. It is believed that the nickel(II) ion added to the mononuclear unit of complex (4) ( $\text{N}_2\text{O}$  chromophore) was subjected to a weaker ligand field than with the  $L_{(\text{salim})(\text{acim})}$  of the mixed terminal imines ( $\text{NO}_2$  chromophore). In the former case, the entering nickel(II) coordinated to the alcoholic oxygen prior to decoordination of both coordinated azomethine and oximate nitrogens to the copper(II) ion. Therefore, the flexibility of the ligand backbone facilitated coordination of the nickel(II) ion although with

a slightly tilted plane from that of the copper(II) ion.<sup>34</sup> This constituted the basis for the preparation of the mixed dinuclear complexes comprising planar copper(II) and octahedral nickel(II) of the type  $L_{(\text{salim})}\text{Cu-Ni}(\text{OAc}) \cdot 2\text{H}_2\text{O}$  or  $L_{(\text{acim})}\text{CuNi}(\text{OAc}) \cdot 2\text{H}_2\text{O}$  where the pentadentate ligand has a terminal salicylalimine and acetylacetonimine, respectively.<sup>35</sup> It is also compatible with the reported<sup>36</sup> observation that the presence of divalent cadmium, lead and mercuric ions greatly accelerate the rate of formation of divalent cobalt, manganese, copper or zinc porphyrins. This was explained as formation of a supramolecular transition state which contains both the entering and departing metal ions through a dissociative mechanism which we suggested for the transmetallic reaction of metal acetylacetonate long ago.<sup>37</sup>

The mononuclear complex (6) was prepared from the reaction of a 2 : 1 molar ratio of compound (1) with copper(II) benzoate. The planar complex (Figure 4), had a broad  $\nu(\text{OH})$  vibration at  $3550\text{--}3200\text{cm}^{-1}$  which is associated with the hydrogen-bonded alcoholic function with the oxygen atom of the coordinated oximato group as reported for this backbone.<sup>18,38</sup> Weak intermolecular coordination by alcoholic oxygen to an adjacent metal ion was suggested<sup>18</sup> for the dimeric  $[\text{KL}_{(\text{salim})}\text{Cu}]_2$ . A weak antiferromagnetic interaction was explained by coupling via the hydrogen bridge.

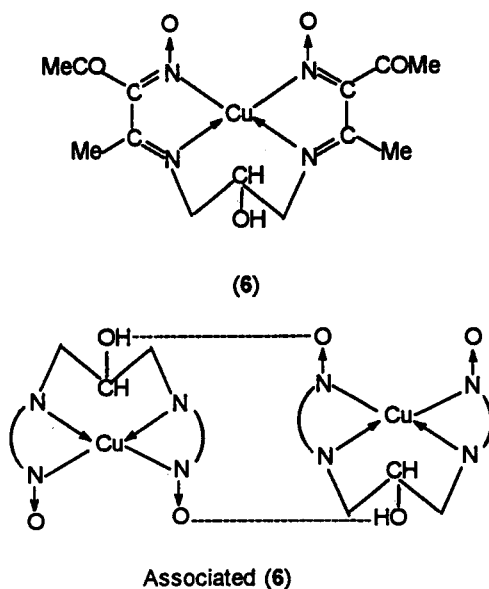

FIGURE 4 Suggested structure for the complex (6) and its associated formation.

This argument also applies to the observed lowering of the magnetic moment of complex (6) (1.15 B.M.) below that usually observed for copper(II) (1.8–2.1 B.M.). In this case, more effective coupling<sup>39</sup> is enhanced by the stronger hydrogen bridge involving the oximate oxygens which is known to mediate a very strong antiferromagnetic exchange interaction.<sup>8–10</sup>

The argument above indicates that bridging of electron density occurs in the mononuclear complexes via the intermolecular bridge, whereas in the case of the dinuclear complexes, the hetero-intramolecular bridges (exogenous and endogenous) are involved (Figure 2). The dinuclear complexes (7)–(11) were prepared to investigate the effect of electron density in the exogenous bridge on the extent of antiferromagnetic interaction. Thus, the 1 : 2 molar ratio reaction of compound (1) with the copper(II) salt (copper phenylacetate, formate, monochloroacetate, dichloroacetate and trichloroacetate of complexes (7), (8), (9), (10) and (11) respectively) produced the corresponding dicopper(II) complex (Figure 2). The  $\nu_{as}$  of the bridging carboxylate (Table II) was shifted<sup>27</sup> to higher frequency by increasing the  $K_a$  of the acid of the corresponding carboxylate ( $K_a$  of acetic acid =  $1.76 \times 10^{-5}$  whereas trichloroacetic acid =  $2.03 \times 10^{-1}$ ). The results of the magnetic moments in Table II suggest that the successive removal of electron density from the exogenous bridge (by the electron-attracting substituent on the acetate) led to an increase in the magnetic moment (from 0.90 B.M. of the acetate bridge to 1.30 B.M. for the trichloroacetate bridge). This trend is quite understandable since removal of electron density from the exogenous bridge should reduce its capacity for conducting the paramagnetic exchange interaction.

Our recent investigations on the supramolecular trends in coordination compounds of vicinal oxime–imine Schiff-base ligands have shown that the oxygen atoms of both the oximate and carbonyl group of the same terminal ligand (the oxygen sites) are capable of intermolecular hydrogen bonding.<sup>13,14</sup> Furthermore, it was reported<sup>40</sup> long ago that phenol, chloroform or propionic acid form adducts with the copper(II) complex of N,N'-ethylene-bis(salicylaldehyde) via the phenoxy oxygen of the ligand. Therefore, the attempted reactions of a 1 : 2 molar ratio of compound (1) with copper salts of benzoic acid (complex (12)) *p*-hydroxybenzoic acid (complexes (13) and (14)) and *p*-aminobenzoic acid (complex (15)) were designed to allow the released acid (from the reaction) to hydrogen bond with the oxygen sites of the dicopper(II) complex. These adducts could be isolated for the case of *p*-hydroxybenzoic acid (complex (13)) which dissociates on standing to complex (14) and *p*-aminobenzoic acid (complex (15)) in contrast with benzoic acid which formed only the dinuclear complex (12). It is suggested that the

hydrogen-bonded acid bridges the dinuclear units of the complex in the equatorial plane (Figure 5). This suggestion is compatible with the broad  $\nu(\text{OH})$ ,  $\nu(\text{C}=\text{O})$  and the splitting of the  $\nu(\text{N}-\text{O})$  vibration as well as with the magnetic moment of these complexes whereby the weakly-associated complexes (13) and (15) have an antiferromagnetic interaction of the same extent as the non-associated complexes (12) and (14).

The cobalt(II) analogue (16) of the supramolecular copper(II) complex (6) was prepared from the 1:1 molar ratio reaction of compound (1) with cobalt(II) acetate, Figure 6. Vibrational evidence for the chelate ring and the hydrogen bonding of the alcoholic function to the oxygen atom of the oximate group are identical with those of the copper(II) complex (Table I). The  $\nu(\text{N}-\text{O})$  vibration is observed at location comparable to that of our earlier finding<sup>41</sup> for the cobalt(II) complex of *N,N'*-ethylenebis(isonitrosoacetylacetonimine). The octahedral structure of this high-spin cobalt(II) complex (16) is based on the broad absorption peak near 500 nm

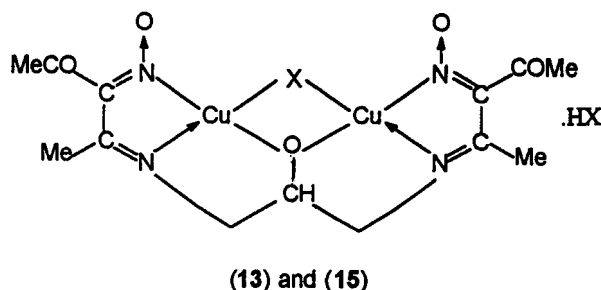

FIGURE 5 Suggested structures for the complexes (13) ( $X = p$ -hydroxybenzoate) and (15) ( $X = p$ -aminobenzoate) with the acid adduct (HX).

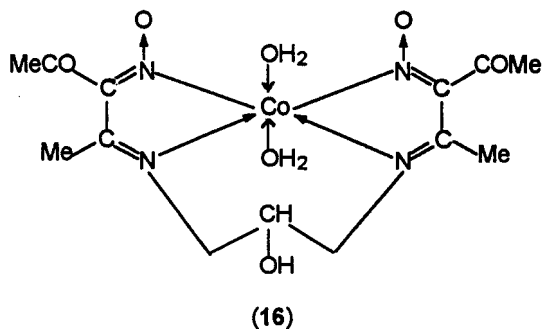

FIGURE 6 Suggested structure for cobalt(II) complex (16) (associated as represented for the copper(II) complex (6)).



characteristic of an octahedral structure of the metal ion.<sup>42</sup> The lowering of the magnetic moment of the complex (2.85 B.M.) from the spin-only value of the high-spin  $d^7$  system (3.87 B.M.) is ascribed to magnetic exchange interactions produced in the dimeric complex via hydrogen bonding with the oximate oximate<sup>8-10</sup> complex as described for the associated complex (6); (Figure 4).

Several pertinent points could be concluded from the foregoing argument concerning the structural implications of the flexible alcoholic backbone: (i) The supramolecular structure of the mononuclear complex  $\text{HLM} \cdot n\text{H}_2\text{O}$  ( $\text{M} = \text{Cu}$ ,  $n = 0$ ,  $\text{M} = \text{Co}$ ,  $n = 2$ ) could be achieved through intermolecular hydrogen bonding, (ii) The formation of the dinuclear complexes (homo- or heteronuclear) takes place via two step reactions in which the coordination of the second metal ion to the alcoholic function induces cooperative coordination (geometrical orientations) by the initially coordinated metal ion, (iii) Less electron density in the bridging carboxylate reduces the anti-ferromagnetic interaction, and (iv) The net result of a flexible backbone is simply more intra- or intermolecular circulation of electron density.

### Acknowledgments

This work was made possible by grant number SC087 of the Kuwait University to which the author is deeply grateful. The author expresses his gratitude to Mr. Magdi A. Hanafi and to the analytical unit of the Faculty of Science (ANALAB) for their experimental help.

### References

- [1] K.D. Karlin and Z. Tyeklar, eds. *Bioinorganic Chemistry of Copper* (Chapman & Hall, New York, London, 1993).
- [2] E.I. Solomon, M.J. Baldwin and M.D. Lowery, *Chem. Rev.* **92**, 521 (1992).
- [3] K.D. Karlin and J. Zubieta, eds. *Copper Coordination Chemistry: Biochemical & Inorganic Perspectives* (Adenine Press, New York, 1993).
- [4] L. Fabbri and A. Poggi, eds. *Transition Metals in Supramolecular Chemistry* (Kluwer Academic Publishers, Dordrecht, 1994), p. 153.
- [5] V.Yu. Kukushkin, D. Tudela and A.J.L. Pombeiro, *Coord. Chem. Rev.* **114**, 169 (1992).
- [6] M.M. Aly, A.O. Baghlaf and N.S. Ganji, *Polyhedron* **4**, 1301 (1985).
- [7] A.O. Baghlaf, M.M. Aly and N.S. Ganji, *Polyhedron* **6**, 205 (1987).
- [8] E. Coacio, J.M. Dominguez-vera, A. Escuer, M. Klinga, R. Kivekas and A. Romerosa, *J. Chem. Soc. Dalton Trans.* **343**, (1995).
- [9] E. Coacio, J.M. Dominguez-vera, A. Escuer, M. Klinga, R. Kivekas and A. Romerosa, *Inorg. Chem.* **33**, 3914 (1994).
- [10] R. Ruiz, J. Sanz, F. Lloret, M. Julve, J. Faus, C. Bois and M. Munoz, *J. Chem. Soc. Dalton Trans.* 3035 (1993).
- [11] M.M. Aly and S.M. Imam, *Polyhedron* **13**, 1907 (1994).
- [12] M.M. Aly and J.J. Stephanos, *Spectrochim Acta* **50A**, 835 (1994); *J. Mol. Struct.* **293**, 75 (1993).

- [13] M.M. Aly and N.I. Al-Shatti, *Transition Met. Chem.* **23**, 361 (1998).
- [14] M.M. Aly, *J. Coord. Chem.* **43**, 89 (1998).
- [15] R. Butcher, G. Diven, G. Erikson, J. Jainski, G.M. Mockler, R.Y. Pozdniakur and E. Sinn, *Inorg. Chim. Acta* **239**, 107 (1995).
- [16] Y. Nishida and S. Kida, *J. Chem. Soc. Dalton Trans.* 2633 (1986).
- [17] W. Mazurek, B.J. Kennedy, K.S. Murray, M.J. O'Connor, J.R. Rodgers, M.R. Snow, A.G. Wedd and P.R. Zwack, *Inorg. Chem.* **24**, 3258 (1985), and references cited therein.
- [18] E. Hilms, H. Elias, H. Paulus and L. Waltz, *J. Chem. Soc. Dalton Trans.* 2169 (1986).
- [19] J.M. Tachagues and D.N. Hendrickson, *Inorg. Chem.* **22**, 2545 (1983).
- [20] K. Dey, *Z. Anorg. Allg. Chem.* **376**, 209 (1970).
- [21] B. Mabad, P. Patrick Cassoux, J.M. Tachagues and D.N. Hendrickson, *Inorg. Chem.* **25**, 1420 (1983).
- [22] N. Kitajima and Y. Moro-oka, *J. Chem. Soc. Dalton Trans.* 2665 (1993).
- [23] M.M. Aly, The 215th Am. Chem. Soc. Meeting, Inorg. 496, March (1998).
- [24] A. Chakravorty, *Coord. Chem. Rev.* **13**, 1 (1974).
- [25] P.E. Kruger, B. Moubaraki, K.S. Murray and E.T. Tiekink, *J. Chem. Soc. Dalton Trans.* 2129 (1994).
- [26] T. Nozaki, H. Ushio, G. Mago, N. Matsumoto, H. Okawa, Y. Yamakawa, T. Anno and T. Nakashima, *J. Chem. Soc. Dalton Trans.* 2339 (1994).
- [27] M. Kato, H.B. Jonassen and J.C. Fannings, *Chem. Rev.* **64**, 99 (1964).
- [28] E. Sinn, *Coord. Chem. Rev.* **5**, 313 (1970).
- [29] B.F. Hoskins, R. Robson and G.A. Williams, *Inorg. Chim. Acta* **16**, 121 (1976).
- [30] T. Ichinose, Y. Nishida, H. Okawa and S. Kida, *Bull. Chem. Soc. Jpn* **47**, 3045 (1974).
- [31] R.D. Gillard and G. Wilkinson, *J. Chem. Soc.* 5339 (1963); M.M. Aly, *J. Inorg. Nucl. Chem.* **9**, 253 (1973).
- [32] H.O. Davies, R.D. Gillard, M.D. Hursthouse and A. Karaulor, *J. Chem. Soc. Dalton Trans.* 2333 (1995).
- [33] A.B.P. Lever, *Inorganic Electronic Spectroscopy* (Elsevier, Amsterdam, 1st edn., 1968), p. 333.
- [34] D.E. Fenton and H. Okawa, *J. Chem. Soc. Dalton Trans.* 1349 (1993).
- [35] M.M. Aly (under publication).
- [36] R.A. Vilaplana and F.G. Vilchez, *J. Chem. Soc. Dalton Trans.* 1779 (1993).
- [37] M.M. Aly, I.M. Issa and L.H. Khalil, *Inorg. Nucl. Chem. Lett.* **8**, 505 (1972); M.M. Aly, *Anal. Chim. Acta* **58**, 467 (1972).
- [38] W. Mazurek, K.J. Berry, K.S. Murray, M.J. O'Connor, M.R. Snow and A.G. Wedd, *Inorg. Chem.* **21**, 3071 (1982).
- [39] J.A. Bertrand, E. Fujita and D.G. Vanderveer, *Inorg. Chem.* **19**, 2022 (1980).
- [40] T. Tanaka, *Bull. Chem. Soc. Jpn* **29**, 93 (1956); *Am. Chem. Soc.* **80**, 4108 (1958).
- [41] M.M. Aly, *Transition Met. Chem.* **15**, 99 (1990).
- [42] Ref. No. 33, p. 318.